

OIL LEVEL GAUGE and SENDER Model # GIOL All Colors Installation Instructions

1. Disconnect battery cable.
2. Install sender in the tank. Run a ground wire from one of the retaining screws to the ground. **A GOOD GROUND IS IMPERATIVE.**
3. The gauge requires a 2 1/16" diameter hole in the instrument panel. Install gauge, making proper ground connection from the center terminal, terminal "G", of the receiver to the battery ground.

CAUTION: Do not use the mounting post for a ground - use terminal "G".

4. Use a good grade of primary ignition wire, well insulated and connect the terminal post on the sender to the terminal post "S" on the gauge.
5. Connect wire from the ignition switch to the terminal post "I" on the receiver.
6. Connect light wire to shortest stud.
7. Reconnect battery cable.

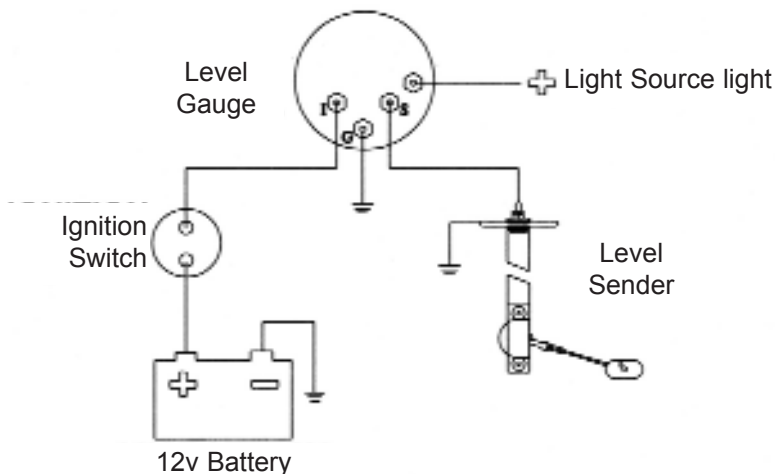

OIL LEVEL GAUGE and SENDER

Trouble Shooting

STEP ONE(this usually solves the problem)- Before you do anything else, check for defective wiring or grounds, as this is the most common cause of failures. Inspect all wiring an terminals. Also, look for corroded or missing engine ground strap connections.

STEP TWO- If pointer in receiver does not move when ignition switch is turned on, check to see that current is actually being carried from the ignition switch to the terminal "I" on the receiver. Also, check to see that paint or corrosion does not prevent proper ground. If pointer still does not move, receiver is defective and must be replaced.

STEP THREE- If receiver meter is not accurate with sender, check the receiver to be sure it is the correct OHM and VOLTAGE.

QUICK- CHECK TROUBLE LOCATOR	
NO INDICATION AT FAR RIGHT	<ol style="list-style-type: none">1. No current to ignition terminal because of broken or disconnected lead.2. Grounded wire between sender and receiver.3. Receiver not grounded.4. Sender defective.
EXCESSIVE POINTER FLUCTUATION	<ol style="list-style-type: none">1. Loose wire connections.2. Defective sender
LOW READING AT ALL TIMES	<ol style="list-style-type: none">1. Wire to sender broken.2. Sender not properly grounded.3. Defective sender.
INDICATES IN ACCURATELY	<ol style="list-style-type: none">1. Incorrect sender.2. Low voltage at receiver terminals.3. Defective sender.
POINTER FLUCTUATES WHEN LIGHTS ARE TURNED ON	<ol style="list-style-type: none">1. Engine not properly grounded.