

## OIL PRESSURE GAUGE and SENDER

Model # LMOP, LMOPW  
Installation Instructions

1. Disconnect battery cable.
2. When the sender has been installed it is automatically grounded to the engine and the engine is usually grounded to the ground side of the battery. If this is not true, proper ground connections should be made. If necessary, a wire can be used for the ground path. **A GOOD GROUND IS IMPERATIVE.**
3. The gauge requires a 2 5/8" diameter hole in the instrument panel. Install gauge making proper ground connection from the center terminal, terminal " - ", of the gauge to battery ground.

**CAUTION:** Do not use the mounting post for a ground - use terminal " - ".

4. Use a good grade of primary ignition wire, well insulated and connect the terminal post on the sender to the terminal post "S" on the gauge.
5. Connect a wire from the ignition switch to the terminal post " + " on the gauge.
6. Reconnect battery cable.

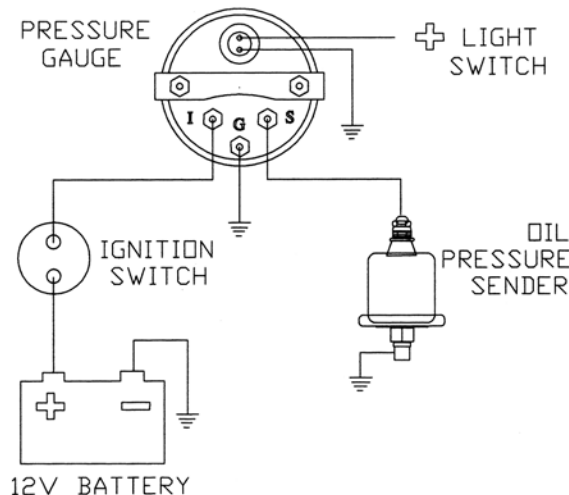

**WARNING: DO NOT USE TEFLON TAPE OR PIPE DOPE** when installing sender. It will inhibit ground connection.