



# **NEW** PLATINUM SERIES THROTTLES

**Arched • Standard • Billet**

**Available in three throttle/shift configurations:**

- **Fully Mechanical**
- **Fully Electric**
- **Mechanical/Electric (Hybrid)**

**LIVORSI**  
CompX Marine Inc. • [livorsi.com](http://livorsi.com)

**847.752.2700**

**[www.livorsi.com](http://www.livorsi.com)**



# Introducing the all NEW PLATINUM SERIES from Livorsi Marine

Designed to be ergonomically comfortable to the operator while being lighter and more compact for fitting into tight spaces. The Platinum Series is finished with a two coat process which prevents corrosion and can be configured for single or multiple engine's for Drives, Transmissions, Jet Drives or Buckets.

## Available in three throttle/shift configurations:

- **Fully Mechanical**
- **Fully Electric**
- **Mechanical/Electric (Hybrid)**

Configurations include one or any combination of the below:

- The use of mechanical 33C or 43C cables for mechanical levers
- Electric configurations use compact direct driven angular sensors, 0-5 Volt electronic sensors or a PWM signal
- The use of a micro switch - for electronic transmission shifting
- Single, twin and triple in-handle trim switch available
- Check with the engine manufacturer or Livorsi Marine for electric control compatibility



Twin engine Billet controls with Contour base and knobs in Black Smoke

Choose from flat or our new contour base; available in an array of colors, chrome or carbon fiber.

Your choice of 1, 2 or 3 switches built-in the knob to actuate your drive, tabs, jack plate, etc.

Push Buttons



Triple Trim Switch



# Fully Mechanical Billet Throttle Control with Contour base in Carbon Fiber

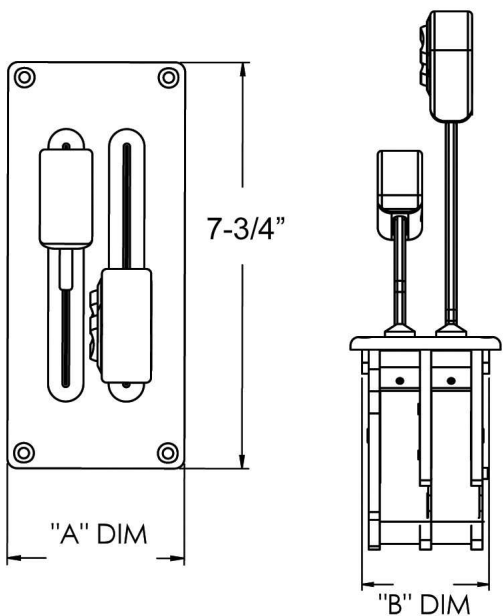

Handles	Overall Size	
	A DIM	B DIM
1	2-1/4" x 7-3/4"	1-7/8" x 6-1/2"
2	3-11/32" x 7-3/4"	2-7/8" x 6-1/2"
3	4-7/16" x 7-3/4"	3-7/8" x 6-1/2"
4	5-17/32" x 7-3/4"	4-7/8" x 6-1/2"
5	6-15/32" x 7-3/4"	5-7/8" x 6-1/2"
6	7-9/16" x 7-3/4"	6-7/8" x 6-1/2"
8	9-9/16" x 7-3/4"	8-7/8" x 6-1/2"
Depth	Mechanical / Hybrid	Electric
	8.125"	6.5"

## Build Your Part Number

Billet Style / electric throttle / mechanical shift / four handle / single switch / contour base / black knobs

<b>B</b>	<b>B</b>
Throttle style	

<b>E</b>
Throttle Actuation

<b>M</b>
Shift Actuation

<b>2</b>
# of Throttle handles

<b>2</b>
# of Shift handles

	<b>S</b>
Switches	

optional

<b>C</b>	<b>B</b>
for a contour base	

<b>B</b>	<b>K</b>
Knob color	

	Code:
Arched	AR
Billet	BB
Standard	ST

full mechanical
full electric
mech throt/elec shift
elec throt /mech shift

	Code:
MM	
EE	
ME	
EM	

	Code:
0	
1	
2	
3	
4	

	Code:
0	
1	
2	
3	
4	

	Code:
no switch	
single	
dual	
triple	
push button	

	Code:
contour chrome	
CB	

NOTE: above in Carbon Fiber

	Code:
black	
blue	
black star	
chrome	
gun metal	
lime	
mustard	
orange	
platinum	
purple	
red	
white	

### Powder Coat Options

Colors:



triple trim switch and push buttons only available on Arched style controls

### Carbon Fiber Base Options



black carbon fiber



silver carbon fiber

Check with the engine manufacturer or Livorsi Marine for electric control compatibility.

