

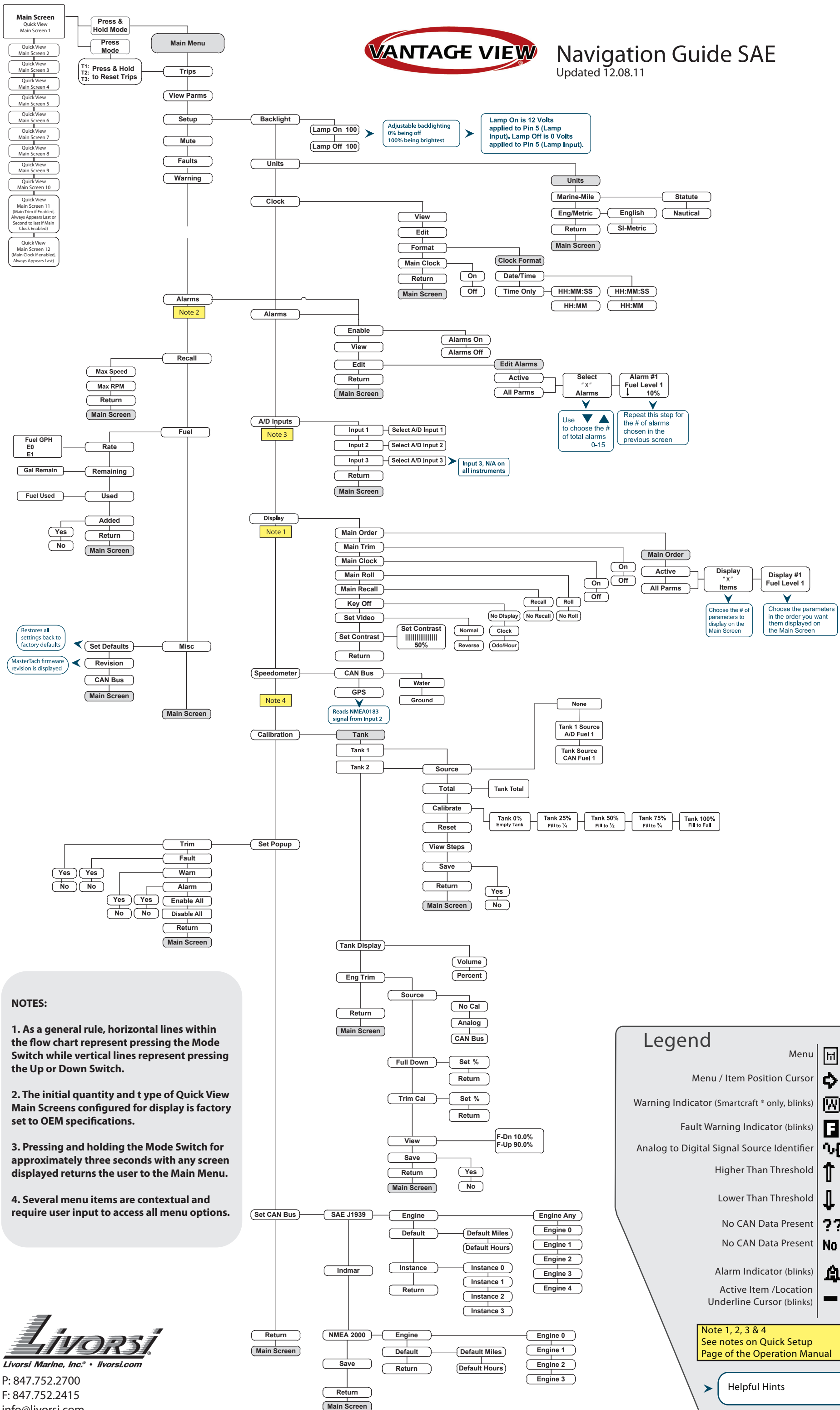

Navigation Guide SAE

Updated 12.08.11



NOTES:

1. As a general rule, horizontal lines within the flow chart represent pressing the Mode Switch while vertical lines represent pressing the Up or Down Switch.
2. The initial quantity and type of Quick View Main Screens configured for display is factory set to OEM specifications.
3. Pressing and holding the Mode Switch for approximately three seconds with any screen displayed returns the user to the Main Menu.
4. Several menu items are contextual and require user input to access all menu options.

Legend

Menu	
Menu / Item Position Cursor	
Warning Indicator (Smartcraft® only, blinks)	
Fault Warning Indicator (blinks)	
Analog to Digital Signal Source Identifier	
Higher Than Threshold	
Lower Than Threshold	
No CAN Data Present	
No CAN Data Present	
Alarm Indicator (blinks)	
Active Item /Location Underline Cursor (blinks)	

Note 1, 2, 3 & 4
See notes on Quick Setup Page of the Operation Manual

Helpful Hints



Livorsi Marine, Inc. • livorsi.com
P: 847.752.2700
F: 847.752.2415
info@livorsi.com
www.livorsi.com

QUICK SETUP

Note 1

Setup Main Screen Parameters

This is where you set the parameters to be displayed on the Main Screen for quick and easy access to information while operating your boat or vehicle.

PATH: Main Menu / Setup / Display / Main Order

- Under the Main Order screen you can choose between Active or All Parm. An arrow will indicated the current choice, press MODE to accept.
- The next screen allows you to select the number of parameters to be displayed. Up to 10 may be chosen. Use the up or down switches to choose quantity. Press MODE to accept. **Note:** TOTAL HOURS or TOTAL MILES will always remain as the first display on the Main Screen.
- The next screen allows you to scroll through the list of parameters. Use the up or down switches to scroll through the list. Press MODE to accept the desired parameters. **Note:** Choose the desired parameters in the order you want them displayed in the Main Screen.

Note 2

Set or Edit Alarms

PATH: Main Menu / Alarms / Edit

or

PATH: Main Menu / Setup / Alarms / Edit

- Choose from Active or All Parm (parameters). An arrow will indicated the current choice, press MODE to accept.
- Select the number of Alarms. Up to 15 may be chosen. Use the up or down switches to choose quantity of alarms. Press MODE to accept.
- The next screen allows you to scroll through all possible parameters to add to the alarm list.
 - Use the up or down switches to scroll through the parameters. Press MODE to choose desired parameter.

A2 indicates Fuel Level 1 is an Analog Input Configured to Input Channel 2



- Once a parameter is chosen, a blinking cursor moves to the Lower Than / Higher Than threshold arrow. Use the up or down switches to change the position of the arrow. Press MODE to accept.
- The blinking cursor now moves to the threshold value. Use the up or down switches to choose the desired value. Press MODE to accept.
- If more than one alarm quantity was chosen, the next alarm setup screen will appear. Repeat steps 3a- 3c.

Note 3

A/D INPUTS

Vantage View accepts a maximum of (2) analog inputs, or (1) analog and (1) NMEA0183 compatible input.

PATH: Main Menu / Setup / A/D Inputs

INPUT 1

Input 1 is the Analog input channel

To set Analog Input

- Select input 1 as the channel the analog sender is connected to
- Once selected, scroll and find the type of sender being used for input channel 1
- After finding the type of sender, a sender range option appears below the parameter name. Scroll to select the appropriate range (resistance) for the sender. After selecting the appropriate range, the A/D Input Menu is ready to edit another input. If all analog inputs are acceptable, use the Main Screen option to return to the Main Screen.

INPUT 2

Input channel 2 is strictly for NMEA0183 compatible GPS antennas and must always be assigned to input channel 2.

Note 4

SPEEDOMETER

Vantage View can read the speed signal from the Master Tach which is supplied by either a CAN message, paddle wheel or GPS signal.

PATH: Main Menu / Setup / Speedometer

CAN BUS

Choose this option if you want the speed signal to read from a CAN source

GPS

Choose this option if you want the speed signal to read from a GPS antenna or paddle wheel. **Note:** Both the paddle wheel or GPS antenna must be NMEA0183 compliant.

To enable the GPS speedometer input

- Set the A/D Input 2 to read NMEA0183 (Path: Main Menu/ Setup/ A/D Inputs/ Input 2)
- Select the GPS option from the menu

• Analog Input Parameters Table			
Parameter	Range	Analog Input	LCD Display Name
Block Pressure	0-200 PSI	240-33Ω/10-180Ω	Block Press
Boost Pressure	0-200 PSI	240-33Ω/10-180Ω	Boost Press
Brake Application Pressure	0-200 PSI	240-33Ω/10-180Ω	Brake Appl Pr
Brake Primary Pressure	0-200 PSI	240-33Ω/10-180Ω	Brake Prim Pr
Brake Secondary Pressure	0-200 PSI	240-33Ω/10-180Ω	Brake Sec Prs
Coolant Level	0-100%	240-33Ω/10-180Ω/0-90Ω	Coolant Level
Engine Oil Level	0-100%	240-33Ω/10-180Ω/0-90Ω	Eng Oil Lvl
Engine Oil Pressure	0-200 PSI	240-33Ω/10-180Ω	Eng Oil Press
Front Air Pressure	0-150 PSI	240-33Ω/10-180Ω/0-90Ω	Front Air
Fresh Water Level	0-100%	240-33Ω/10-180Ω/0-90Ω	Fresh Wat Lvl
Fuel Delivery Pressure	0-200 PSI	240-33Ω/10-180Ω	Fuel Press
Fuel Level 1	0-100%	240-33Ω/10-180Ω/0-90Ω/Centroid 3	Fuel Level 1
Fuel Level 2	0-100%	240-33Ω/10-180Ω/0-90Ω/Centroid 3	Fuel Level 2
Generic Level	0-100%	240-33Ω/10-180Ω/0-90Ω	Misc Level
Generic Pressure	0-400 PSI	240-33Ω/10-180Ω	Misc Pressure
Hydraulic Oil Level	0-100%	240-33Ω/10-180Ω/0-90Ω	Hydr Oil Lvl
Hydraulic Oil Pressure	0-200 PSI	240-33Ω/10-180Ω	Hydr Oil Pres
Inside Temperature	-4 - 104 °C	10K Thermistor	Inside Air Tm
Outside Temperature	-4 - 104 °C	10K Thermistor	Outside Air Tm
Rear Air Pressure	0-150 PSI	240-33Ω/10-180Ω/0-90Ω	Rear Air
Rudder Angle	-100° - 100°	240-33Ω/10-180Ω/0-90Ω	Rudder Angle
Steering Angle	-100° - 100°	240-33Ω/10-180Ω/0-90Ω	Steer Angle
Transmission Oil Level	0-100%	240-33Ω/10-180Ω/0-90Ω	Trns Oil Lvl
Transmission Oil Pressure	0-400 PSI	240-33Ω/10-180Ω	Trns Oil Pres
Trim	0-100%	240-33Ω/10-180Ω/0-90Ω/167-10Ω	Trim Position
Washer Fluid Level	0-100%	240-33Ω/10-180Ω/0-90Ω	Washer Level
Waste Water Level	0-100%	240-33Ω/10-180Ω/0-90Ω	Waste Wat Lvl
Water Temperature	-4 - 104 °C	10K Thermistor	Water Temp
GPS Compass	0-360°	NMEA 0183	GPS Compass
GPS Heading	0-360°	NMEA 0183	GPS Heading
GPS Speed	0-200 MPH	NMEA 0183	GPS Speed
Latitude	-180° - 180°	NMEA 0183	Latitude
Longitude	-180° - 180°	NMEA 0183	Longitude
Speed (Water Reference)	0-200 MPH	NMEA 0183	Water Speed
Water Depth	0-999'	NMEA 0183	Water Depth
Water Temperature	-4 - 104 °C	NMEA 0183	Water Temp