

REDLINE OIL PRESSURE GAUGE and SENDER

Model # RLOP100/20, RLOP80/10 All Colors

Installation Instructions

1. Disconnect battery cable.
2. The gauge requires a 2 1/16" diameter hole in the instrument panel. Install gauge, making proper ground connection from the center terminal, terminal "G", of the gauge to the battery ground.
CAUTION: Do not use the mounting post for a ground - use terminal "G".
3. When the sender has been installed it is automatically grounded to the engine and the engine is usually grounded to the negative side of the battery. If this is not true, proper ground connections should be made. If necessary, a wire can be used for the ground path. **A GOOD GROUND IS IMPERATIVE.**
4. Use a good grade of primary ignition wire, well insulated and connect the terminal post on the sender to the terminal post "S" on the gauge.
5. Connect wire from the ignition switch to the terminal post "I" on the receiver.
6. Connect light wire to shortest stud.
7. Reconnect battery cable.

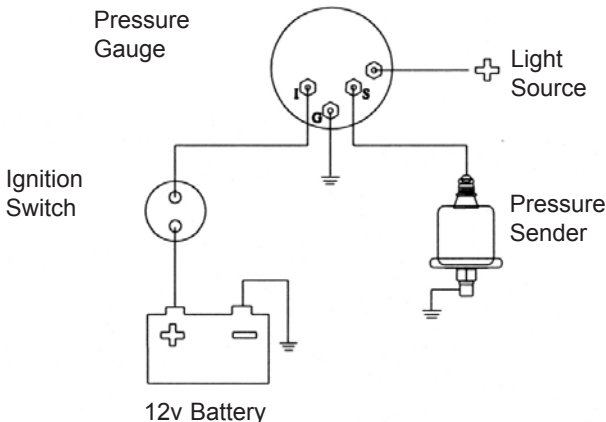

WARNING: DO NOT USE TEFLON TAPE OR PIPE DOPE when installing sender. It will inhibit ground connection.

REDLINE OIL PRESSURE GAUGE and SENDER

Trouble Shooting

STEP ONE (this usually solves the problem) - Before you do anything else, check for defective wiring or grounds, as this is the most common cause of failures. Inspect all wiring and terminals. Also, look for corroded or missing engine ground strap connections.

STEP TWO - If pointer in receiver does not move when ignition switch is turned on, check to see that current is actually being carried from the ignition switch to the terminal "I" on the receiver. Also, check to see that paint or corrosion does not prevent proper ground. If pointer still does not move, receiver is defective and must be replaced.

STEP THREE - If receiver meter is not accurate with sender, check the receiver to be sure it is the correct OHM and VOLTAGE.

QUICK- CHECK TROUBLE LOCATOR	
NO INDICATION AT FAR RIGHT	<ol style="list-style-type: none">1. No current to ignition terminal because of broken or disconnected lead.2. Grounded wire between sender and receiver.3. Receiver not grounded.4. Sender defective.
EXCESSIVE POINTER FLUCTUATION	<ol style="list-style-type: none">1. Loose wire connections.2. Defective sender
LOW READING AT ALL TIMES	<ol style="list-style-type: none">1. Wire to sender broken.2. Sender not properly grounded.3. Defective sender.
INDICATES IN ACCURATELY	<ol style="list-style-type: none">1. Incorrect sender.2. Low voltage at receiver terminals.3. Defective sender.
POINTER FLUCTUATES WHEN LIGHTS ARE TURNED ON	<ol style="list-style-type: none">1. Engine not properly grounded.